

## Welcome

PixelArt provides a highly flexible way to convert any video source from the small screen to a potentially huge stage. Every part of the system is intelligent and fully programmable. This makes PixelArt quick to install, resilient to link failures and easily upgradeable to take advantage of the latest features.

## Overview

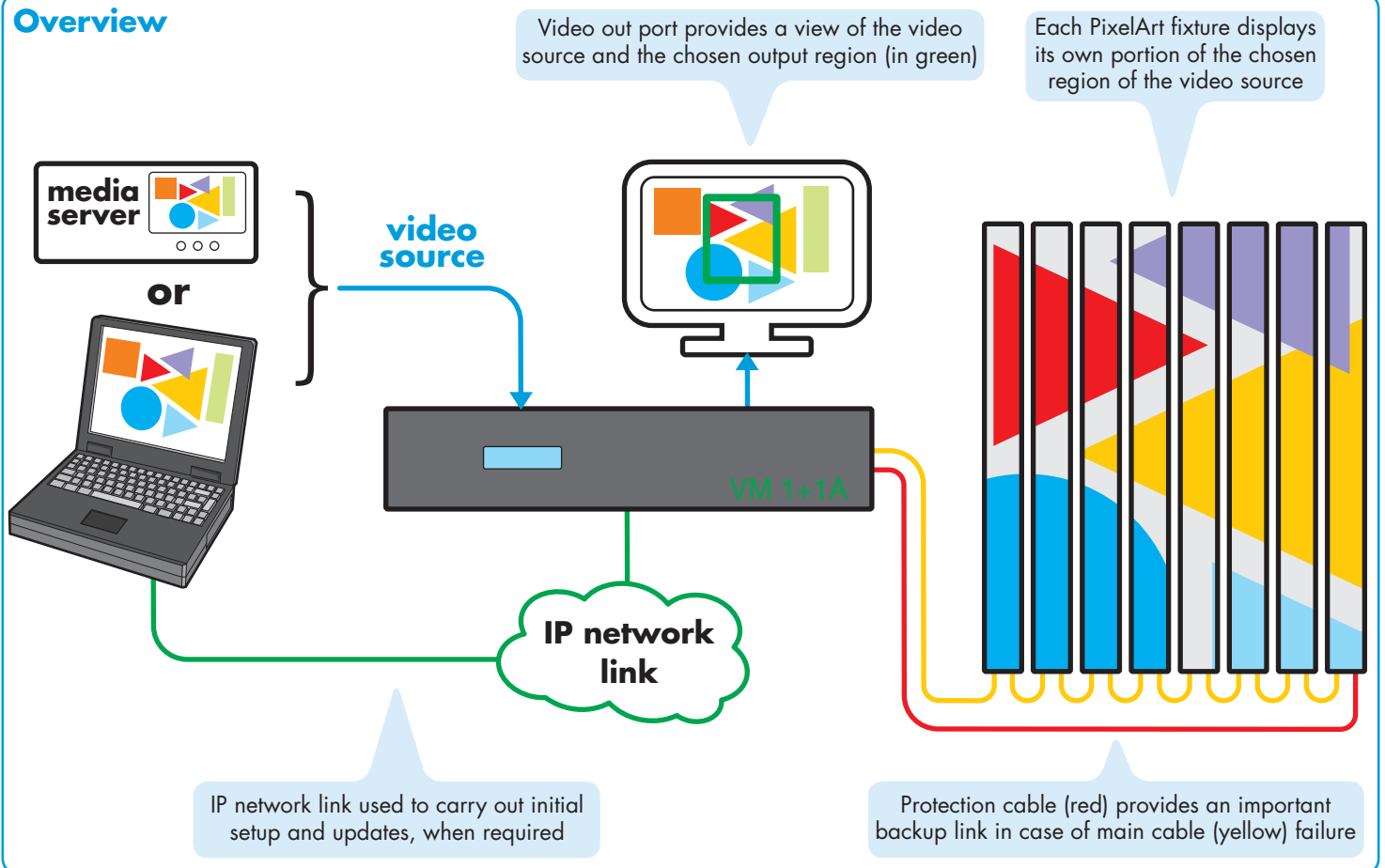

## Contents

Quick start checklist for a typical installation	page 2
Key items in the PixelArt system	page 2
PixelArt Batten mounting	page 3
PixelArt Batten signal cabling	page 4
PixelArt Batten power cabling and status indicators	page 5
Video Mapper link cabling	page 6
Video Mapper video and power cabling	page 7
Video Mapper startup	page 8
Video Mapper menu	page 8
PixelArt Setup Utility	page 9
PixelArt Setup Utility: five key functions	page 10
Crosshairs, grids and solid colour	page 11
PixelArt fixture orientation	page 12
PixelArt fixture positioning	page 13
Troubleshooting	page 14

## Checklist

See page 2 for a complete checklist summary of all actions required to create a new PixelArt installation.

## Quick start checklist for a typical installation

To create a successful installation, the PixelArt system requires a combination of mechanical, electrical and software configurations. This quick start checklist runs through the general order of tasks required for a typical installation:

- 1 Mount the PixelArt fixtures using standard or custom brackets. see page 3
- 2 Make daisy-chain power and signal connections between the PixelArt fixtures and also connect the main signal link from the Video Mapper (V-PORT MAIN socket) to port A of the first PixelArt fixture. see pages 4 & 5
- 3 Set up a network link between the Video Mapper and the configuration computer. see page 6
- 4 On the Video Mapper, connect your video source to the appropriate video input socket (DVI In or VGA In) and attach a DVI monitor to the DVI Out socket. see page 7
- 5 Power up the PixelArt fixtures, the Video Mapper, the DVI monitor, the video source and/or the computer.
- 6 On the computer, run the PixelArt Setup Utility and set the 'Auto-Number Fixtures' option to 'On' for just five seconds and then switch it 'Off'. see page 9
- 7 In the PixelArt Setup Utility, use the 'Video Input Properties' (within the 'Video Mapper' menu) option to select the appropriate video input source and define the required video crop area. see page 10
- 8 In the PixelArt Setup Utility, optionally select the 'Fixture Discovery' tab and click the 'Discover Fixtures' button to determine the current arrangement of the connected PixelArt fixtures. see page 10
- 9 In the PixelArt Setup Utility, select the 'Fixture Mapping' tab and where necessary, arrange the PixelArt fixture positions and orientations within the video space to match their physical locations. When ready, click the Transmit All button to transfer your new mapping details to the Video Mapper and fixtures. see page 10
- 10 In the PixelArt Setup Utility, when your configuration is complete, you are strongly recommended to save the details so that they are immediately available in the future. From the File menu, select the 'Save Fixture Mapping As' option to create a .csv file containing your configuration. see page 10
- 11 On the Video Mapper, when all settings have been made, use the 'Configuration' > 'Save' option to ensure that the unit begins using the same settings automatically at every power up. see page 8
- 12 Connect the standby link (if used) from the last PixelArt fixture to the V-PORT STANDBY socket of the Video Mapper. see page 4

The PixelArt fixtures should now be displaying the portion of the video source as defined by the crop area settings. If they are not, then please refer to the **Troubleshooting** section.

see page 14

## Key items in the PixelArt system

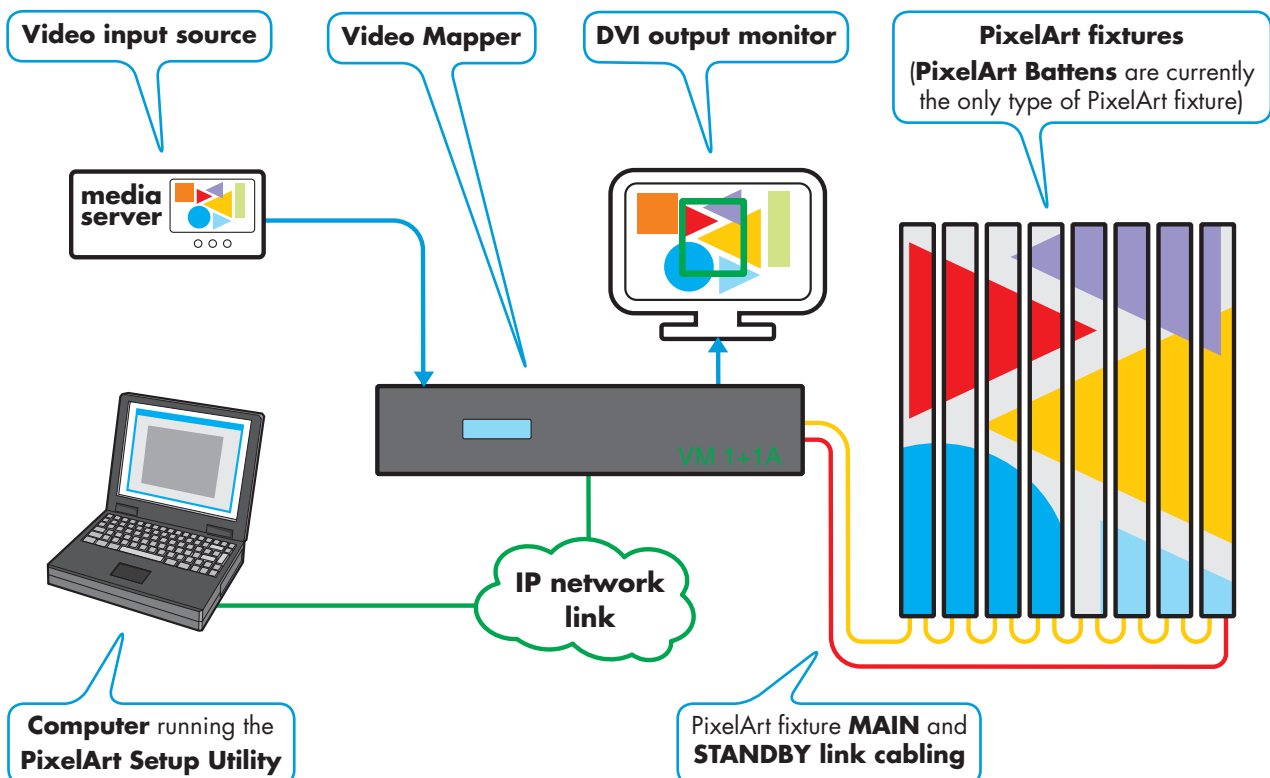

## PixelArt Batten mounting

### Supplied Omega brackets

Each PixelArt Batten is supplied with two 'Omega' brackets (plus fixings) which attach at the top and bottom of the rear panel.

#### For each bracket

- 1 Insert the two screws into the sockets at the top left and bottom right holes of the fixing area. Leave them loose.
- 2 Securely fit the required clamps to each of the omega brackets using the supplied bolts, washers and Nyloc® nuts.
- 3 Offer the bracket to the screws so that the curved slots engage, then rotate the bracket anti-clockwise. Tighten the screws.
- 4 Insert the two twist lock bolts into the top right and bottom left holes and twist them clockwise to lock the bracket in place.
- 5 Double check that each bracket is secure and use a safety wire (see below).

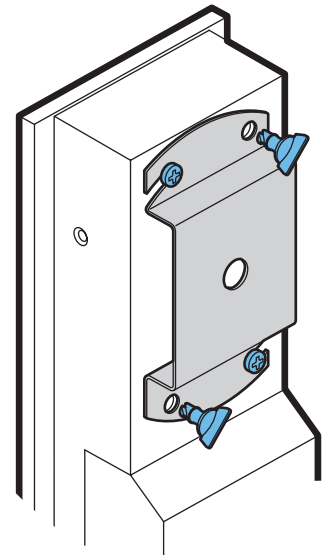

### Optional U-brackets

Optional U-brackets allow greater tilted angles for PixelArt Battens.

#### For each bracket

- 1 Place the supplied fibre washers between the U-bracket and the side holes of the PixelArt Batten.
- 2 Place the metal washers onto the screws and insert them through the bracket and the fibre washers into the side holes.
- 3 Tighten the screws and double check that the bracket is secure.
- 4 Use a safety wire (see left).

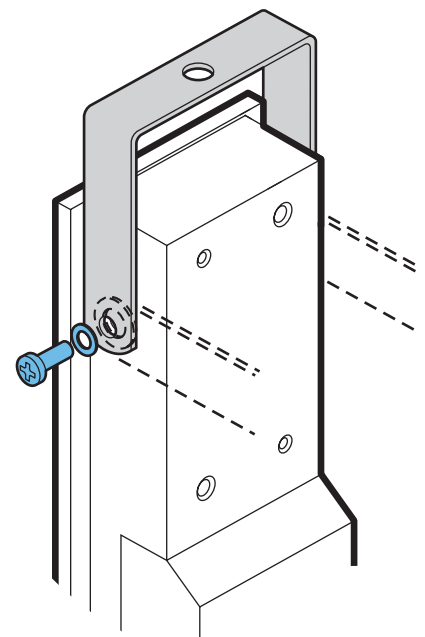

### Use a safety wire

Ensure that all PixelArt Battens mounted off-ground are protected using a secure safety wire (rated to at least 15Kg, 33lbs) through the eyelet situated adjacent to the connection panel.

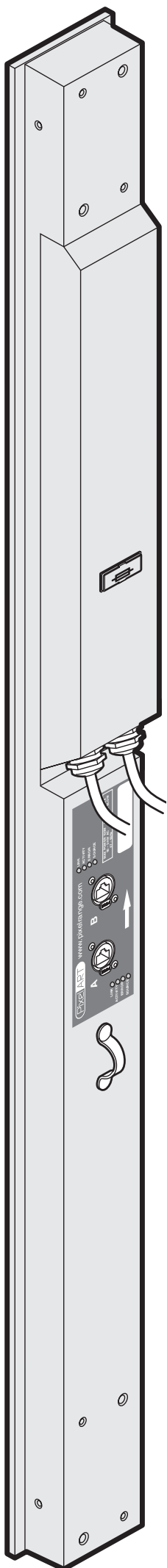
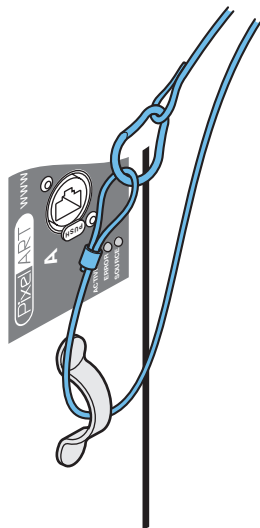

## PixelArt Batten signal cabling

- Industry standard Category 5e or 6 (CAT 5e or CAT 6) twisted pair network cable terminated at either end with standard RJ45 connectors or Neutrik® EtherCon® NE8MC (for more robust linking). Either cross-over or straight wired cables may be used for each link - every batten configures the signals accordingly.
- Maximum length of 100 metres (328 feet) between any two battens (or between the Video Mapper and a batten). Every PixelArt Batten reconditions the signal before transmitting it to the next.
- The maximum number of PixelArt fixtures permissible within a single installation is one hundred.
- **IMPORTANT:** Do not connect ANY PixelArt Batten cabling to an Ethernet network. Such an interconnection will not cause damage but will result in both the PixelArt system and the network functioning incorrectly.

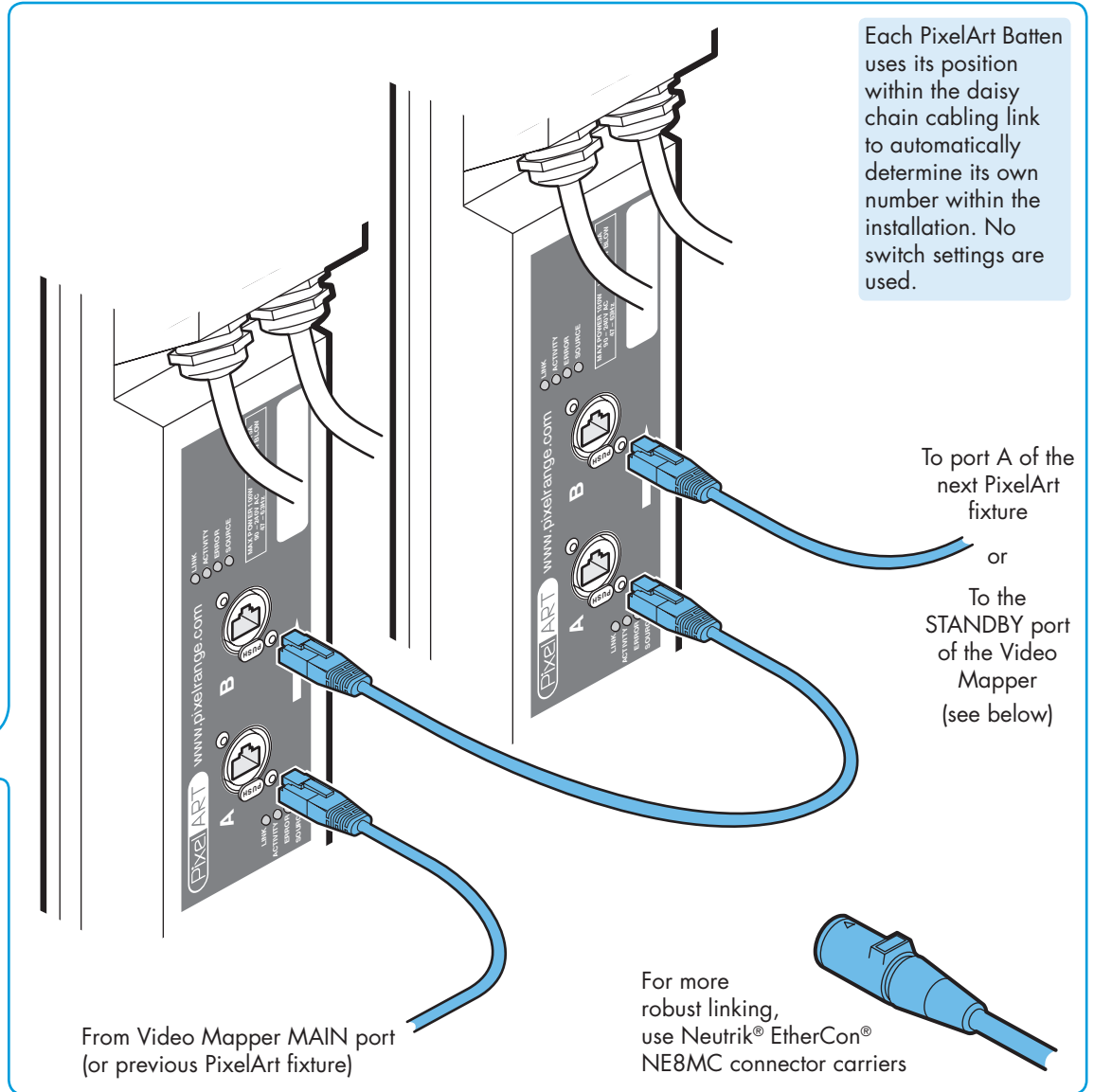
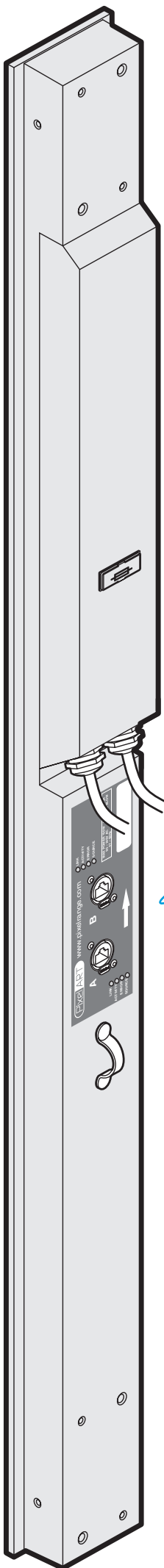

## Standby cabling

You have the option to run a link cable from the last PixelArt fixture back to the STANDBY port of the Video Mapper. This provides a failsafe loop against link cable failure. In such an occurrence, the system will automatically recognise the loss of signal and re-route from the other direction up to the lost cable. The battens will all reconfigure themselves accordingly and operate around the failure with no loss of output on either side of the break.

**IMPORTANT:** When setting up a new installation, do not connect the standby cable to the Video Mapper until the PixelArt fixtures have been taken out of auto-numbering mode. Otherwise the battens will incorrectly begin auto numbering themselves from both ends of the installation.

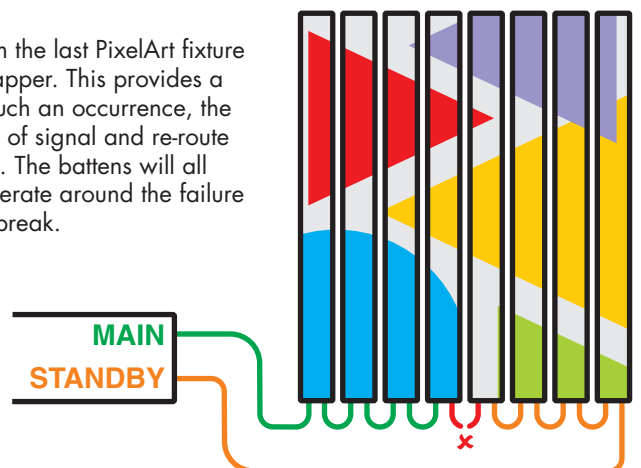

## PixelArt Batten power cabling and status indicators

**IMPORTANT: Do not connect more than 20 PixelArt Battens in a single power daisy chain.**

Input voltage: 90 to 264V AC, 47 to 63Hz autosensing

Earth leakage: 0.22mA

Connectors required: Neutrik PowerConn® NACFC3A and NACFC3B

Power requirements:	@ 230V/50Hz	@ 115V/60Hz
Standby	35 watts	35 watts
Maximum (const.)	100 watts	100 watts
Start up (peak*)	<40 amps	<40 amps

\* The peak value occurs only at first power up and lasts only for a period measured in microseconds. Adjustments may need to be made to supply circuit breakers when (up to 20) PixelArt Battens are daisy-chained, causing them all to draw the peak simultaneously.

### PixelArt Batten fuse

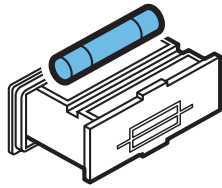

Size: 5 x 20mm  
Rating: 3.15A (slow)  
250VAC

### PixelArt Batten status indicators

**LINK:** When on, indicates that a valid cable link is present.

**ACTIVITY:** Indicates that data is being received - this indicator is usually always on due to the continually streamed data.

**ERROR:** Illuminates when errors are discovered within the data stream.

**SOURCE:** Indicates where data is being received from:

SHORT FLASH (known as a ping) - No valid data present.

FAST FLASH - data received from Video Mapper MAIN port.

SLOW FLASH - data received from Video Mapper STANDBY port.

DOUBLE FLASH - data is looped back on same cable, i.e. final batten (without protection) or batten is adjacent to a cable break.

*Note: During normal use, when the main and standby links are connected, the SOURCE indicators for the A and B ports (on every PixelArt fixture) will confirm to which side of the link loop they are connected: main (fast flash) or standby (slow flash).*

LINK   
ACTIVITY   
ERROR   
SOURCE 

**IMPORTANT: Do not connect more than 20 PixelArt Battens in a single power daisy chain.**

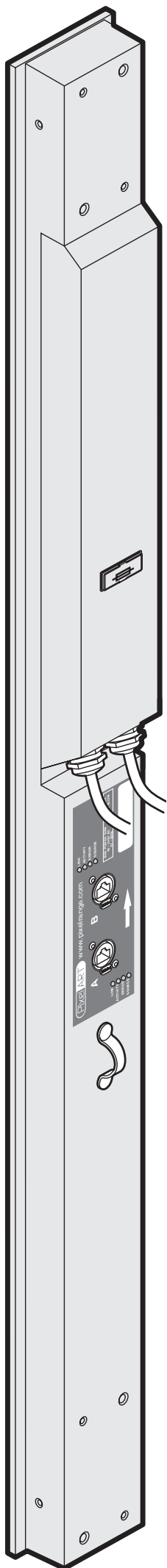
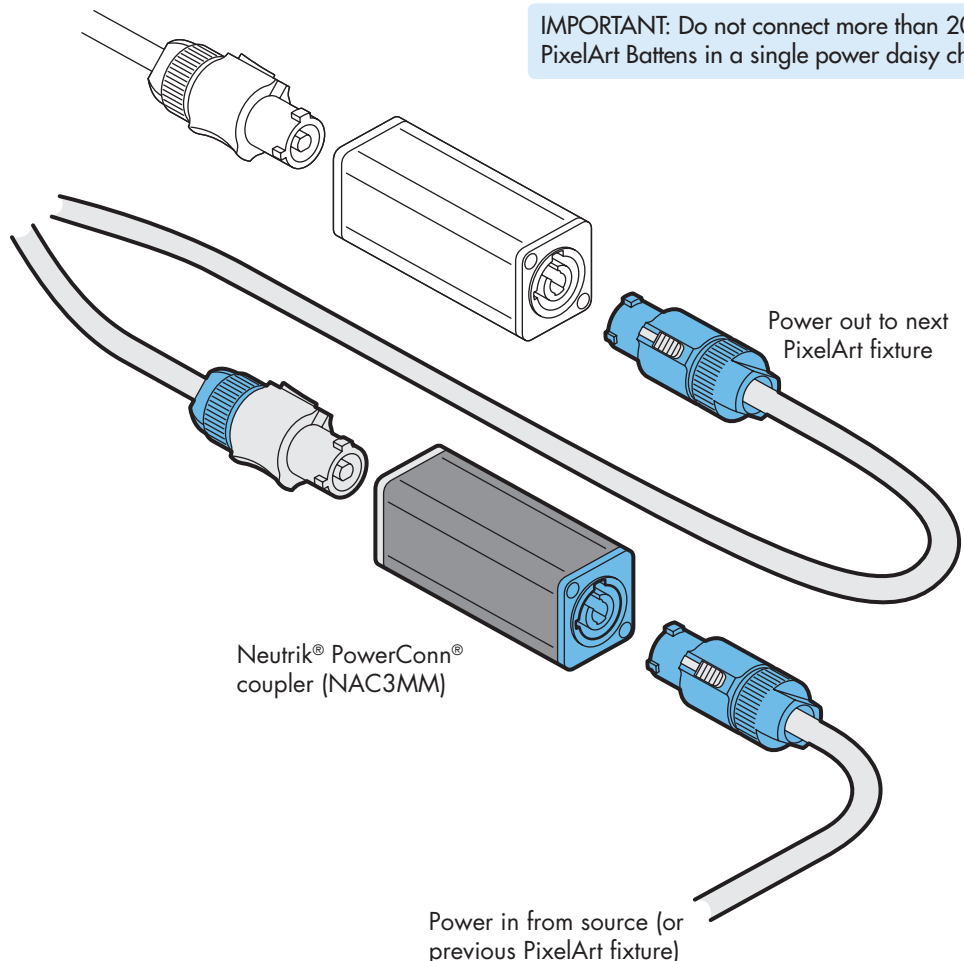

# Video Mapper link cabling

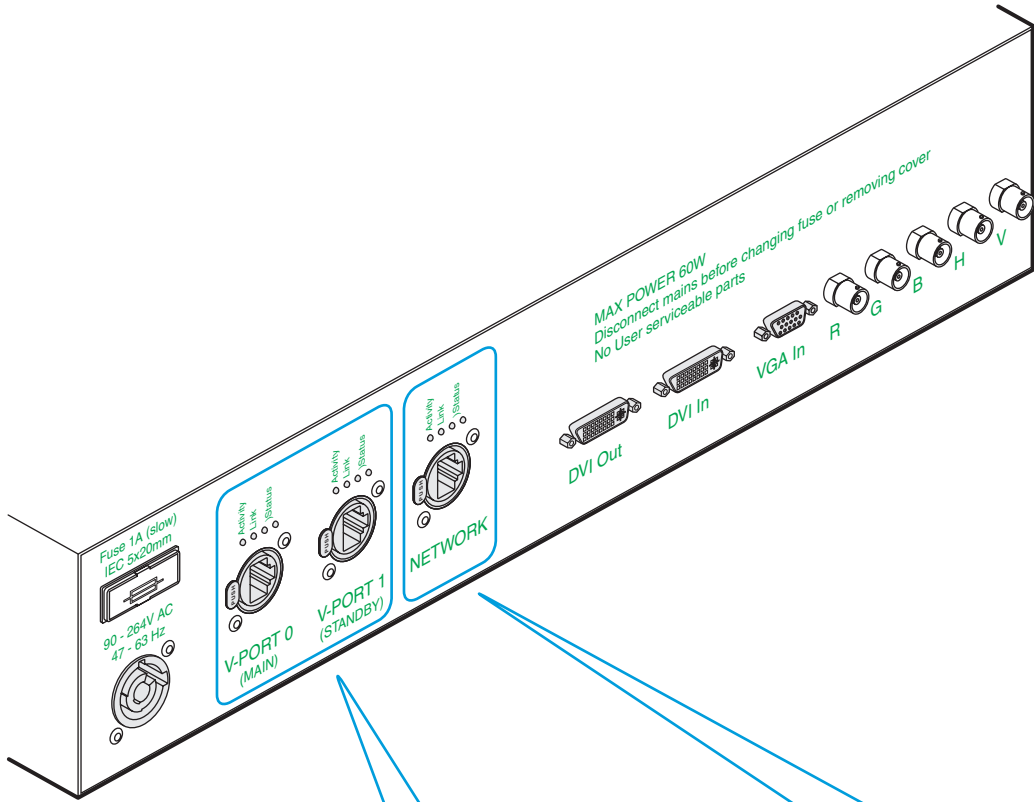

## V-PORT links to PixelArt fixtures

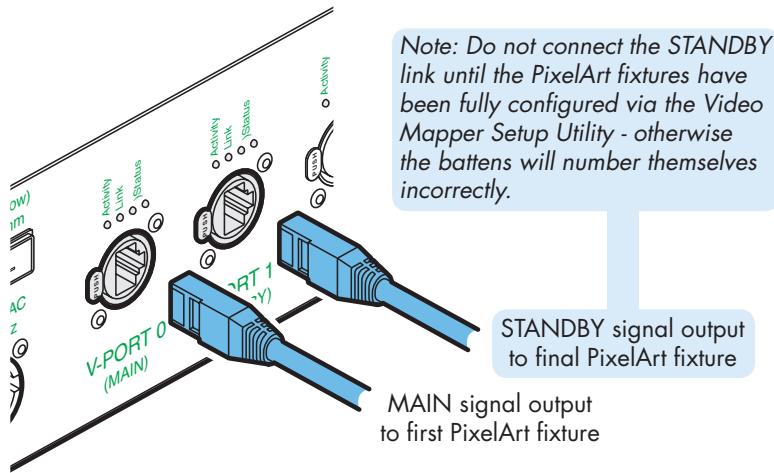

### V-PORT status indicators

- LINK:** When on, indicates that a valid cable link is present.
- ACTIVITY:** Indicates that data is being transmitted - this indicator is usually always on due to the continually streamed data.
- STATUS:** Reserved for future use.

## Computer network link

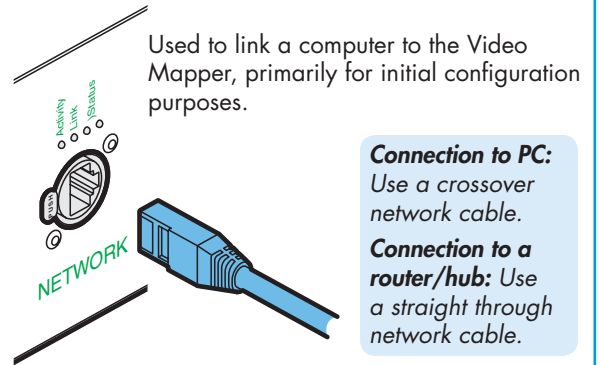

You can either connect your computer directly to the Video Mapper or indirectly via a network router/hub. Use CAT5e or CAT6 cable (see crossover note above).

Depending on its configuration, the Video Mapper will either attempt to automatically find itself a suitable network address or will use a pre-configured setting (determined by 'Network Settings' within the Video Mapper menu - see page 8).

During automatic searches, the Video Mapper will try to configure itself according to the connected network (using DHCP or *Dynamic Host Configuration Protocol*). In automatic mode, if no other devices are discovered, the Video Mapper will timeout and use a default address and subnet mask, usually: 2.0.0.20 and 255.0.0.0 respectively.

*Note: The search will take longer if no network is connected.*

### Network status indicators

- LINK:** When on, indicates that a valid cable link is present.
- ACTIVITY:** Indicates that data is being transceived.
- STATUS:** Reserved for future use.

# Video Mapper video and power cabling

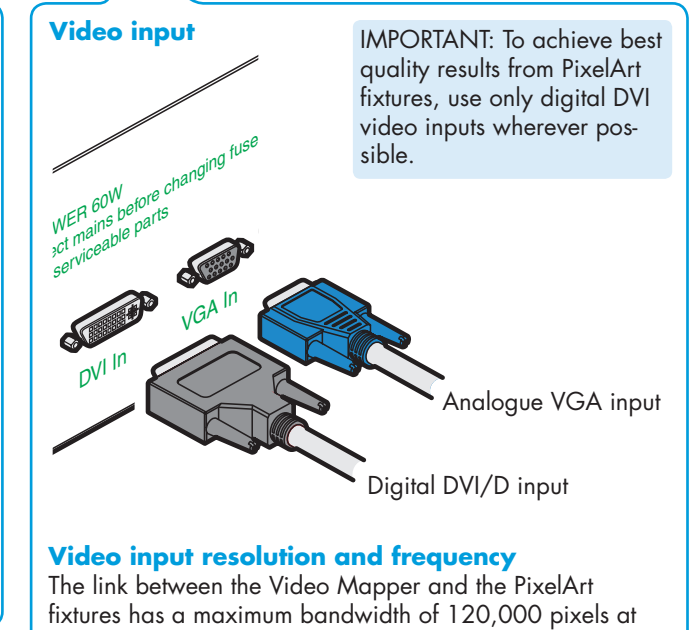
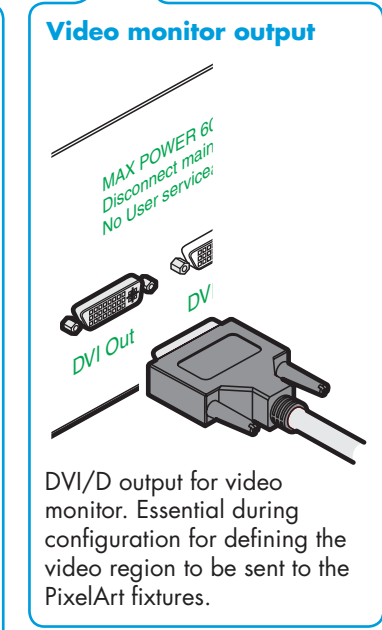
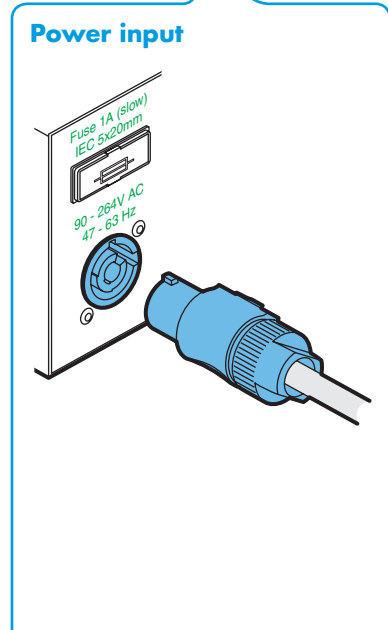
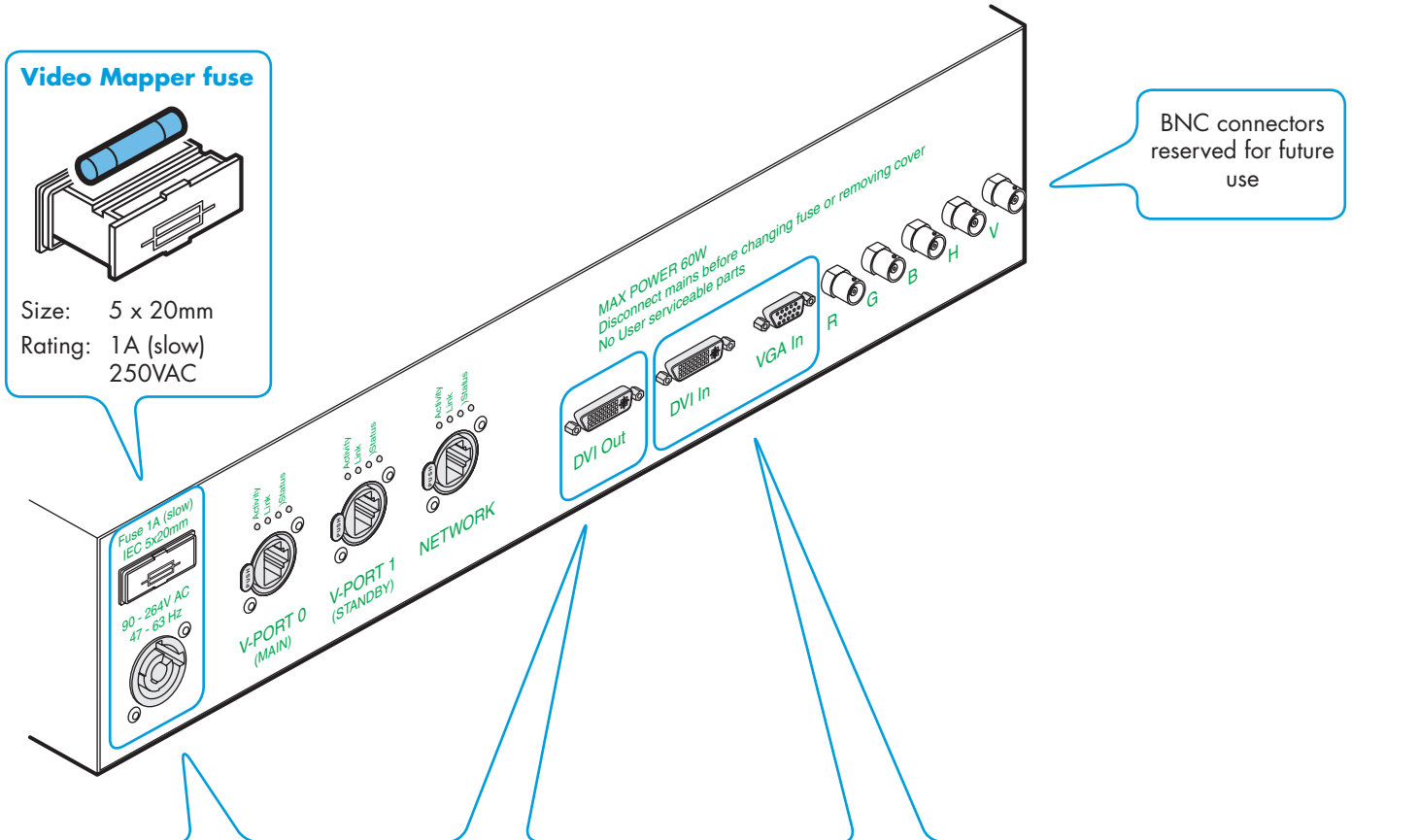

**IMPORTANT:** To achieve best quality results from PixelArt fixtures, use only digital DVI video inputs wherever possible.

## Power requirements

Input voltage:	90 to 264V AC, 47 to 63Hz autosensing	
Earth leakage	0.22mA	
Connector required:	Neutrik PowerConn® NACFC3A	
Power requirements:	@ 230V/50Hz	@ 115V/60Hz
Maximum (const.)	60 watts	60 watts
Start up (peak*)	<40 amps	<40 amps

\* The peak value occurs only at first power up and lasts only for a period measured in microseconds.

## Video input resolution and frequency

The link between the Video Mapper and the PixelArt fixtures has a maximum bandwidth of 120,000 pixels at 25Hz (frames per second). This equates to a quarter of an 800 x 600 video input or just under half of a 640 x 480 input. The actual portion of the video input that is sent to the PixelArt fixtures is determined using the Crop Area settings within the PixelArt Setup Utility (see page 9). The Video Mapper automatically takes every third frame from the video input. Therefore, the optimum video input resolution is **75Hz** (in order to achieve an ideal 25Hz (25 frames per second) output to the PixelArt fixtures).

## Video Mapper startup

As soon as power is applied to the Video Mapper, it will either attempt to automatically find itself a suitable network address or will use a pre-configured setting as determined by 'Network Settings > Network Setup > Set Network Mode'.

During automatic searches, the Video Mapper will try to configure itself according to the connected network (using DHCP or *Dynamic Host Configuration Protocol*). In automatic mode, if no other devices are discovered, the Video Mapper will timeout and use a default address and subnet mask, usually: **2.0.0.20** and **255.0.0.0** respectively.

You can preset a network address and subnet mask using 'Network Settings > Network Setup > Set IP Address / Set Subnet Mask'.

*Note: The automatic search will take longer if no network is connected.*

## Video Mapper menu

The Video Mapper menu allows you to configure various aspects of operation.

### To enter and use the menu

- 1 From the initial screen display that shows the firmware version and network address, press the **ENTER** (⌂) button to enter the menu. The top line of the screen will show the first menu item: *Pattern Tools*.
- 2 Use the **DOWN** (⌵) and **UP** (⌶) buttons to move between the menu options and press the **ENTER** (⌂) button when the required menu option is displayed.
- 3 Within the chosen menu option, again, use the **DOWN** and **UP** buttons to display the required sub-option (or setting) and press the **ENTER** button to select it. When a setting is changed, the display will show *SET* as confirmation.
- 4 Use the **BACK** (⌴) button to exit from a menu option to the previous level.

PixelArt 0x 132  
Starting

Video Mapper  
firmware version

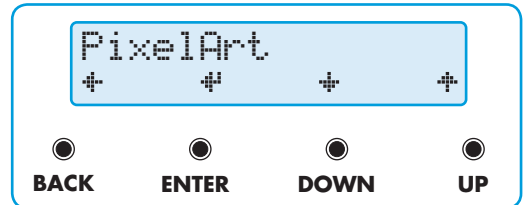

**IMPORTANT:** When making changes that you wish to keep after the next power up, visit the 'Configuration' option and select 'Save'. This is especially vital when changing network addresses as it may affect the next power up.

### Menu layout

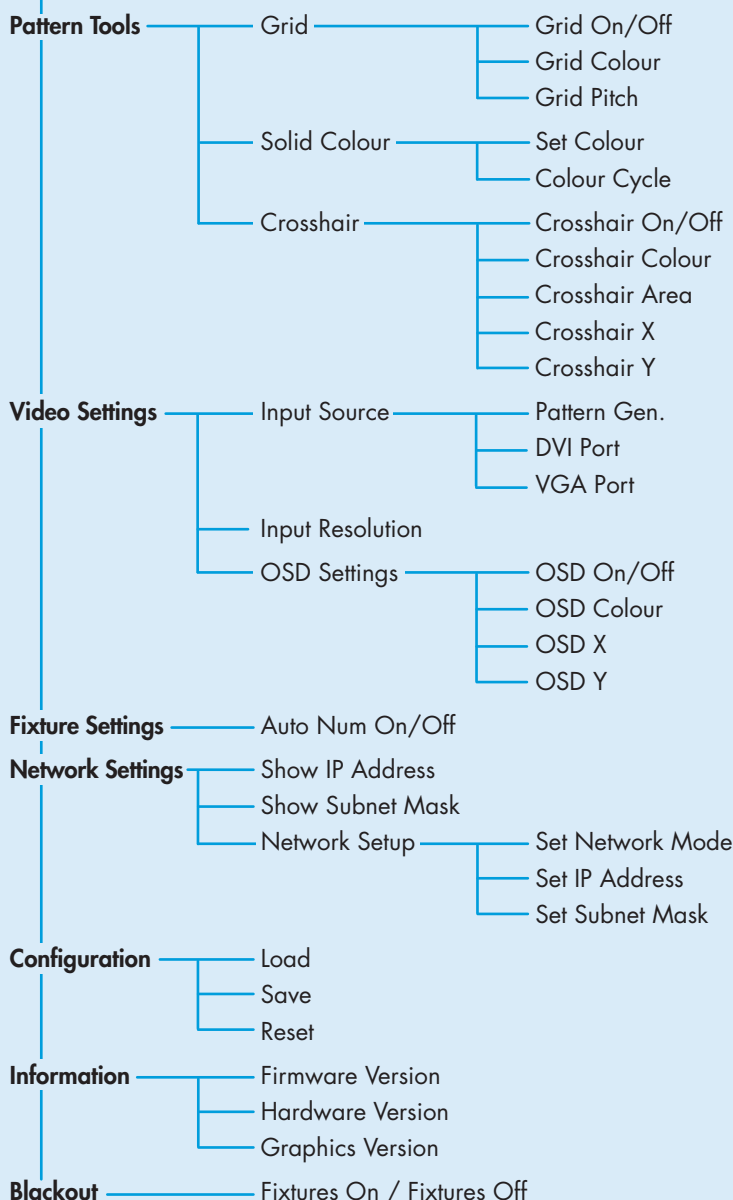

#### Pattern Tools

Controls the Video Mapper's internal effects generator and enables you to superimpose a grid, solid colour fills and/or a crosshair onto the PixelArt fixture display. The grid and the crosshairs are particularly useful when configuring new installations - see page 11.

#### Video Settings

Determines various aspects of the video input and output, including the main video source, the input resolution and information items that can be overlaid (On Screen Display or *OSD*) onto the DVI output monitor screen.

**Fixture Settings** - Allows you to place the connected fixtures in and out of auto-numbering mode.

#### Network Settings

Allows you to adjust the network address and subnet mask settings used by the Video Mapper when linked to a computer. Address setting is manual as standard.

**Configuration** - Allows you to save, load or reset all Video Mapper settings within internal non-volatile memory.

**Information** - Provides details about the revisions on the various major components within the Video Mapper.

**Blackout** - Enables you to immediately place all connected PixelArt fixtures into blackout.

## PixelArt Setup Utility

The PixelArt Setup Utility is used during initial configuration and can be run on any Windows-based computer (Windows® XP or Vista required with Java6 or later) or any Apple Mac (with Java 5 or later) that is network linked to the Video Mapper.

### Starting the PixelArt Setup Utility

- 1 Insert the supplied disc into CD-ROM drive of the connected computer.
- 2 View the contents of the CD-ROM and run the PixelArt Setup Utility application.

When the utility starts, you will see the main screen 

### Video Mapper communication

Check that the network address shown in the Video Mapper IP address section matches the address shown in the startup display of the Video Mapper. If the network addresses do not match or there is no address shown in the section, then there may be a communication problem. Please see the Troubleshooting section on page 14 for details.

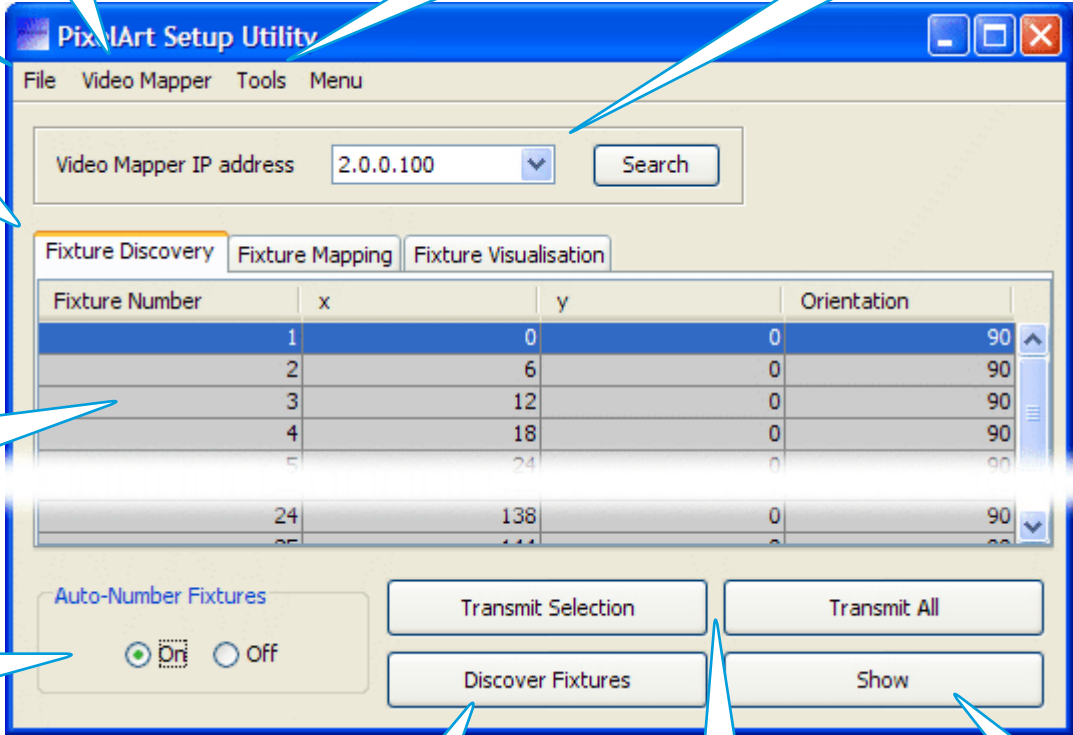

Use this menu to save or load fixture mapping files

Use this menu to confirm the source video input, define the crop area and save all settings to the Video Mapper

Use the 'Initialise Fixtures' option within the 'Tools' menu if one or more fixtures behave erratically

Shows the network address of the Video Mapper. Use Search to find a newly connected Video Mapper

The three main tabs allow you to: see the preliminary arrangement of the PixelArt fixtures; define new arrangements and view a visualisation

The central area shows the fixture positions and orientations, either as values or as a visual representation depending on the chosen tab

Use this option to enable and disable fixture auto numbering

Click the 'Video Mapper' menu & select 'Video Input Properties'

Set the video input source here

Use this button to discover the current x,y and orientation values for all of the connected PixelArt fixtures

Use these buttons to send all or some fixture mapping details to the PixelArt fixtures

Use this button to create a visual representation of the fixture mapping (not currently implemented)

Configure the crop area size and position here. The Total field will turn red if your size settings exceed the 120,000 pixel maximum.  
*Note: When defining a crop box, ensure that it remains within the total video input area.*

**PixelArt Setup Utility**  
 File Video Mapper Tools Menu

Video Mapper IP address 2.0.0.100 Search

Fixture Discovery Fixture Mapping Fixture Visualisation

Fixture Number	x	y	Orientation
1		0	90
2		6	90
3		12	90
4		18	90
5		24	90
...			
24		138	90
25		144	90
...			
28		180	90
29		186	90
...			
32		222	90
33		228	90
...			
36		264	90
37		270	90
...			
40		306	90
41		312	90
...			
44		348	90
45		354	90
...			
48		390	90
49		396	90
...			
52		432	90
53		438	90
...			
56		474	90
57		480	90
...			
60		516	90
61		522	90
...			
64		558	90
65		564	90
...			
68		600	90
69		606	90
...			
72		642	90
73		648	90
...			
76		684	90
77		690	90
...			
80		726	90
81		732	90
...			
84		768	90
85		774	90
...			
88		810	90
89		816	90
...			
92		852	90
93		858	90
...			
96		894	90
97		900	90
...			
100		936	90
101		942	90
...			
104		978	90
105		984	90
...			
108		1020	90
109		1026	90
...			
112		1056	90
113		1062	90
...			
116		1104	90
117		1110	90
...			
120		1146	90
121		1152	90
...			
124		1188	90
125		1194	90
...			
128		1230	90
129		1236	90
...			
132		1272	90
133		1278	90
...			
136		1314	90
137		1320	90
...			
140		1356	90
141		1362	90
...			
144		1404	90
145		1410	90
...			
148		1446	90
149		1452	90
...			
152		1488	90
153		1494	90
...			
156		1530	90
157		1536	90
...			
160		1572	90
161		1578	90
...			
164		1614	90
165		1620	90
...			
168		1656	90
169		1662	90
...			
172		1704	90
173		1710	90
...			
176		1746	90
177		1752	90
...			
180		1788	90
181		1794	90
...			
184		1830	90
185		1836	90
...			
188		1872	90
189		1878	90
...			
192		1914	90
193		1920	90
...			
196		1956	90
197		1962	90
...			
200		2004	90
201		2010	90
...			
204		2046	90
205		2052	90
...			
208		2088	90
209		2094	90
...			
212		2130	90
213		2136	90
...			
216		2172	90
217		2178	90
...			
220		2214	90
221		2220	90
...			
224		2256	90
225		2262	90
...			
228		2304	90
229		2310	90
...			
232		2346	90
233		2352	90
...			
236		2388	90
237		2394	90
...			
240		2430	90
241		2436	90
...			
244		2472	90
245		2478	90
...			
248		2514	90
249		2520	90
...			
252		2556	90
253		2562	90
...			
256		2604	90
257		2610	90
...			
260		2646	90
261		2652	90
...			
264		2688	90
265		2694	90
...			
268		2730	90
269		2736	90
...			
272		2772	90
273		2778	90
...			
276		2814	90
277		2820	90
...			
280		2856	90
281		2862	90
...			
284		2904	90
285		2910	90
...			
288		2946	90
289		2952	90
...			
292		2988	90
293		2994	90
...			
296		3030	90
297		3036	90
...			
300		3072	90
301		3078	90
...			
304		3114	90
305		3120	90
...			
308		3156	90
309		3162	90
...			
312		3204	90
313		3210	90
...			
316		3246	90
317		3252	90
...			
320		3288	90
321		3294	90
...			
324		3330	90
325		3336	90
...			
328		3372	90
329		3378	90
...			
332		3414	90
333		3420	90
...			
336		3456	90
337		3462	90
...			
340		3504	90
341		3510	90
...			
344		3546	90
345		3552	90
...			
348		3588	90
349		3594	90
...			
352		3630	90
353		3636	90
...			
356		3672	90
357		3678	90
...			
360		3714	90
361		3720	90
...			
364		3756	90
365		3762	90
...			
368		3804	90
369		3810	90
...			
372		3846	90
373		3852	90
...			
376		3888	90
377		3894	90
...			
380		3930	90
381		3936	90
...			
384		3972	90
385		3978	90
...			
388		4014	90
389		4020	90
...			
392		4056	90
393		4062	90
...			
396		4104	90
397		4110	90
...			
400		4146	90
401		4152	90
...			
404		4188	90
405		4194	90
...			
408		4230	90
409		4236	90
...			
412		4272	90
413		4278	90
...			
416		4314	90
417		4320	90
...			
420		4356	90
421		4362	90
...			
424		4404	90
425		4410	90
...			
428		4446	90
429		4452	90
...			
432		4488	90
433		4494	90
...			
436		4530	90
437		4536	90
...			
440		4572	90
441		4578	90
...			
444		4614	90
445		4620	90
...			
448		4656	90
449		4662	90
...			
452		4704	90
453		4710	90
...			
456		4746	90
457		4752	90
...			
460		4788	90
461		4794	90
...			
464		4830	90
465		4836	90
...			
468		4872	90
469		4878	90
...			
472		4914	90
473		4920	90
...			
476		4956	90
477		4962	90
...			
480		5004	90
481		5010	90
...			
484		5046	90
485		5052	90
...			
488		5088	90
489		5094	90
...			
492		5130	90
493		5136	90
...			
496		5172	90
497		5178	90
...			
500		5214	90
501		5220	90
...			
504		5256	90
505		5262	90
...			
508		5304	90
509		5310	90
...			
512		5346	90
513		5352	90
...			
516		5388	90
517		5394	90
...			
520		5430	90
521		5436	90
...			
524		5472	90
525		5478	90
...			
528		5514	90
529		5520	90
...			
532		5556	90
533		5562	90
...			
536		5604	90
537		561	

# PixelArt Setup Utility: five key functions

## 1 Auto-Numbering fixtures

When beginning a new installation, it is vital to briefly place the connected PixelArt fixtures into auto-numbering mode so that they can assign themselves unique fixture numbers, according to their positions within the daisy chain cable link. Once complete you do not need to auto number the PixelArt fixtures again, unless any fixtures are added, removed or moved.

*Note: It is important that the Auto-Number Fixtures option is switched Off before the standby link is made from the final PixelArt fixture to the Video Mapper.*

### To auto-number the PixelArt fixtures

- 1 In the lower left corner of the PixelArt Setup Utility window, in the Auto-Number Fixtures section, click the On option.
- 2 After five seconds, click the Off option.

## 2 Confirming the source video input

The Video Mapper provides a choice of two video inputs: DVI digital or VGA analogue. Of the two input types, the DVI option provides a much greater image quality. You need to confirm to the Video Mapper which input is being used.

### To confirm the source video input

- 1 In the PixelArt Setup Utility window, click the 'Video Mapper' menu and select the 'Video Input Properties' option to display the Video Input Setup window.
- 2 In the Video Input section of the window, select either the DVI or the RGB/VGA option, as appropriate.  
  
If you select the RGB/VGA option, then you will also need to confirm the resolution of the video source. Click the down arrow of the Resolution box and select the appropriate setting.
- 3 When the appropriate settings have been made, click the Set button to send the data to the Video Mapper.

## 3 Defining the video crop area

The PixelArt fixtures display a portion of the total input video source and that portion is defined by the crop area. Once defined, all PixelArt fixture coordinates are determined relative to the top left hand corner of the crop area.

*Note: The Video Mapper provides a crosshair tool to assist you to relate positions on the output video monitor (and the PixelArt fixtures) with pixel coordinates - see the next page for details ➔*

### To define the crop area

- 1 In the PixelArt Setup Utility window, click the 'Video Mapper' menu and select the 'Video Input Properties' option to display a dialog box (shown on page 9)
- 2 In the Crop Area section, enter the required position of the top left corner of the crop area using the x and y fields. In each case, you are entering the number of pixels across (x) and down (y) from the top left corner of the total video space area (i.e. 800 x 600; 640 x 480, etc.).
- 3 Now define the size of the crop area using the Width and Height fields. Again, these are measured in pixels and the total area must not exceed 120,000, (e.g. width = 400 x height = 300) which is the upper limit that can be sent to the PixelArt fixtures.

*Note: Ensure that your combined crop area size and position settings result in the crop area lying within the overall video input space, i.e. so that a portion of the crop area does not overhang any of the video space boundaries.*

- 4 When the appropriate values have been entered, click the Set button to send the data to the Video Mapper. On the DVI monitor you will see the green outlined crop area change within the total video space to reflect your values. This is now the screen area that will be sent to the PixelArt fixtures.

## 4 Fixture mapping

Thanks to the flexible manner in which the PixelArt fixtures are designated, you can configure any PixelArt fixture to occupy any position (and any 90 degree rotation) within the video space defined by the crop area. This is called *fixture mapping* and is a key feature of the PixelArt system. There are two main ways to determine fixture mapping:

- By using just the PixelArt Setup Utility,  
or
- By using a spreadsheet and the PixelArt Setup Utility.

**See also:** *The Discovering Fixtures section below; page 11 for details about crosshairs and grids; pages 12 and 13 for important details about fixture orientation and positioning.*

### To map fixtures using only the PixelArt Setup Utility

- 1 In the PixelArt Setup Utility window, click the 'Fixture Mapping' tab.
- 2 For each fixture entry, click your cursor in the required x, y or Orientation field and edit the entry as necessary. Press your keyboard's Enter key to fix the new value.
- 3 Repeat step 2 for each entry that needs to be changed.
- 4 When all changes have been made, either click the Transmit All button or highlight one or more fixture entries and click the Transmit Selection button.

### To map fixtures using a spreadsheet and the utility

- 1 Use a spreadsheet such as Microsoft Excel to create a simple file with four columns and as many rows as there are PixelArt fixtures. From left to right the columns represent: Fixture number, x, y and orientation.  
  
Alternatively, in the PixelArt Setup Utility, save the current discovered fixtures to a .csv file (using the 'Save Discovered Fixture Map As' option in the File menu) and then open that file within Excel and use it as a template.
- 2 Once your mapping details are complete, save the file with a .csv file ending.
- 3 In the PixelArt Setup Utility, open the saved file using the 'Load Fixture Mapping' option in the File menu.  
  
The new details will be shown within the 'Fixture Mapping' tab.
- 4 Click the 'Transmit All' button to send the data to the fixtures.

## 5 Save settings to the Video Mapper

Once all settings have been made, you need to save them within the Video Mapper so that it can be used independently of the computer.

### To save settings to the Video Mapper

- 1 In the PixelArt Setup Utility window, click the 'Video Mapper' menu and select the 'Save Current Setup to Video Mapper' option to transfer all configuration details.

## Discovering fixtures

When beginning a new installation, it is common, but not essential to discover the current configuration of all connected PixelArt fixtures. From this starting point it can be more straightforward to adjust the configuration to suit your required layout, particularly if the PixelArt fixtures have been wired in a logical sequence.

### To perform a fixture discovery

- 1 In the PixelArt Setup Utility window, click the 'Fixture Discovery' tab.
- 2 Click the 'Discover Fixtures' button. Within a short while, the x, y and orientation coordinates for each PixelArt fixture will be updated within the list.

## Crosshairs, grids and solid colour

The Video Mapper is able to generate and superimpose items over the source video input to assist you during configuration. As well as being able to apply a solid colour to the whole video space, you will find the crosshairs particularly useful when defining the crop area and the grid invaluable when initially testing the fixture mapping.

### Using crosshairs when defining the crop area

When configuring a new installation it is necessary to define the size and position of the crop area (within the total video space) that will form the area displayed by the PixelArt fixtures.

The Video Mapper provides a set of crosshairs to assist in locating the required coordinates of the crop area. The crosshairs are superimposed on the video input as seen on the connected DVI video monitor and also, when they enter the crop area, on any connected PixelArt fixtures that are mapped into the same area.

You have the choice of viewing crosshair coordinates relative to the entire video space origin (absolute) or relative to the origin of the crop area. The former is useful when defining the crop area, the latter is more useful when testing/locating areas once the crop area has been fully defined.

The current **x** or **y** coordinates (absolute or crop area) of the crosshairs are shown on the Video Mapper display and these can be used directly within the PixelArt Setup Utility.

#### To use the crosshairs

- 1 On the Video Mapper, enter the Pattern Tools menu and select the 'Crosshair On/Off' option. Choose the 'On' setting.

*Note: You can also change the colour for the crosshairs.*

- 2 Select the 'Crosshair Area' option and choose either 'Absolute' or 'Crop Area 1' as required.
- 3 Select the 'Crosshair X' or 'Crosshair Y' option, as appropriate, and increase or decrease the position value until the crosshair arrives at the required position, as seen on the monitor and possibly the PixelArt fixtures.
- 4 Read off the value shown on the display and use this when defining the crop area or locating a section within the crop area.
- 5 Repeat steps 3 and 4 for the other crosshair.

### Using the grid when fixture mapping

The grid feature provided by the Video Mapper is useful when initially mapping fixtures or when testing fixtures because it will quickly highlight any fixtures that have been mapped or mounted incorrectly.

#### To use the grid

- 1 On the Video Mapper, enter the Video Settings menu and select the Input Source option. Choose the 'Pattern Generator' option.
  - 2 Now enter the Pattern Tools menu and select the 'Grid On/Off' option. Choose the 'On' setting.
- Note: You can also change the colour for the grid.*
- 3 Select the 'Grid Pitch' option and adjust the grid spacing from 0 to 20. If the PixelArt fixtures are correctly mapped and positioned, you should see a contiguous grid across all fixtures.

*Note: When you have finished with the grid, you need to change the input source back to either 'DVI port' or 'VGA port' within the 'Video Settings' > 'Input Source' menu.*

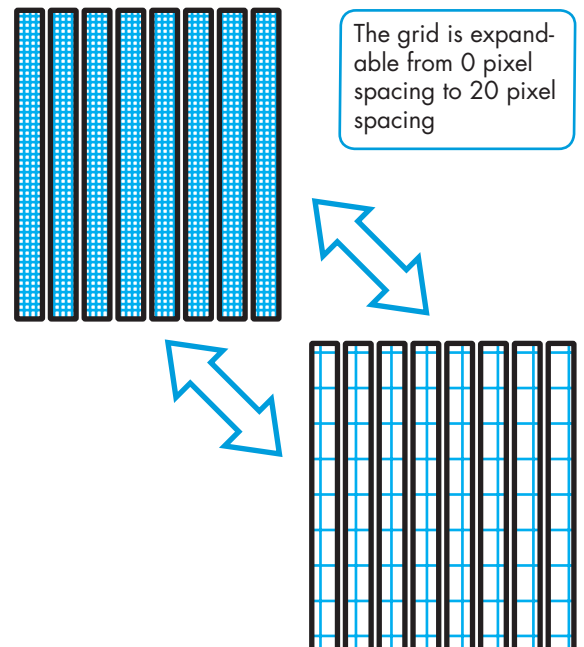
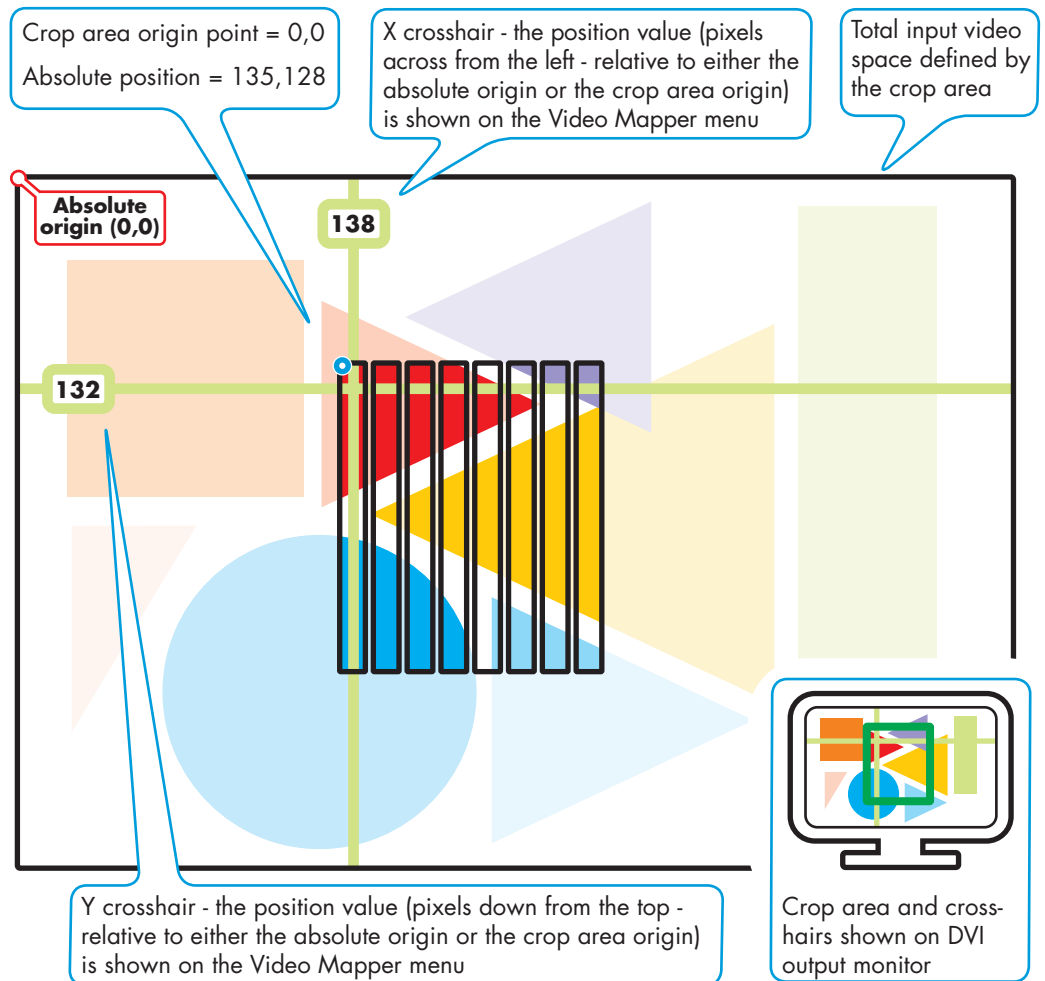

## PixelArt fixture orientation

You can physically arrange each PixelArt fixture in any of four rotational positions: 0, 90, 180 or 270 degrees, going clockwise relative to the horizontal plane. To match the physical arrangements, you need to inform the PixelArt fixtures themselves (via the PixelArt Setup Utility and the Video Mapper) which way they are positioned.

Each PixelArt fixture maintains a logical origin point at its top left hand corner, irrespective of its rotation. This is to simplify fixture positioning information and also to ensure that the video image remains true, regardless of how each PixelArt fixture is arranged.

In the representations shown here, the power cables are used to indicate the direction of the fixture.

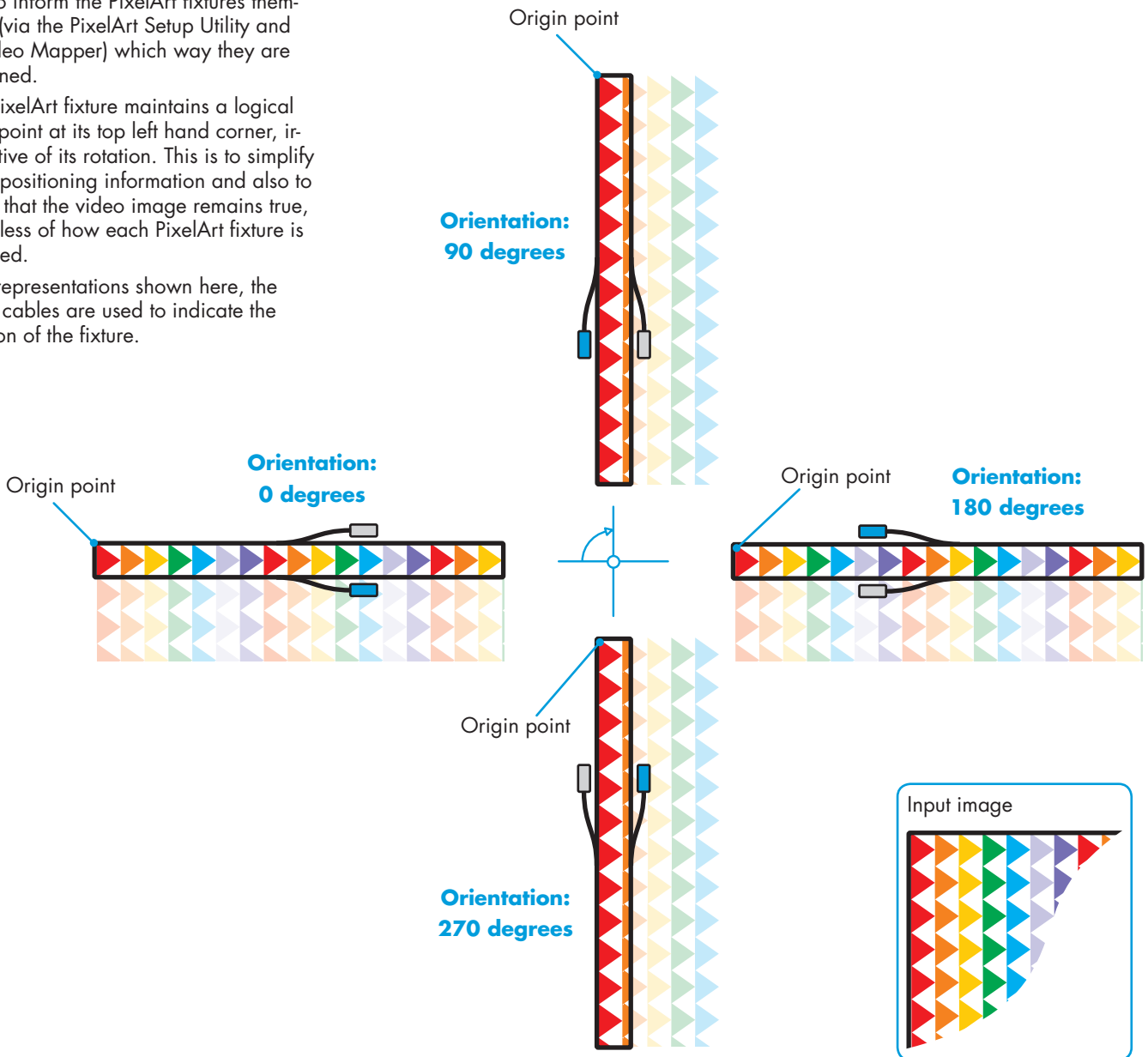

### Orienting PixelArt fixtures

You can set the orientation for each PixelArt fixture using either:

- The Fixture Mapping tab of the PixelArt Setup Utility,
- or
- A spreadsheet (such as Microsoft® Excel®) to create a (.csv) file that can be loaded into the PixelArt Setup Utility.

See page 13 for details.

## PixelArt fixture positioning

You can place each PixelArt fixture anywhere within the video space defined by the crop area.

Each PixelArt fixture's position within the video space is totally independent of its location in the control cable daisy chain, although it is common for the two to coincide.

Three values are required to position a PixelArt fixture within the video space:

- a horizontal **x** coordinate (measured in pixels)
- a vertical **y** coordinate (measured in pixels), and
- an orientation (measured in degrees)

The origin point of the video space is always in the top left hand corner (of the crop area) and similarly, the origin point for each PixelArt fixture is also always in the top left hand corner, regardless of their respective rotation settings.

Note: Each PixelArt Batten measures 6 x 72 pixels

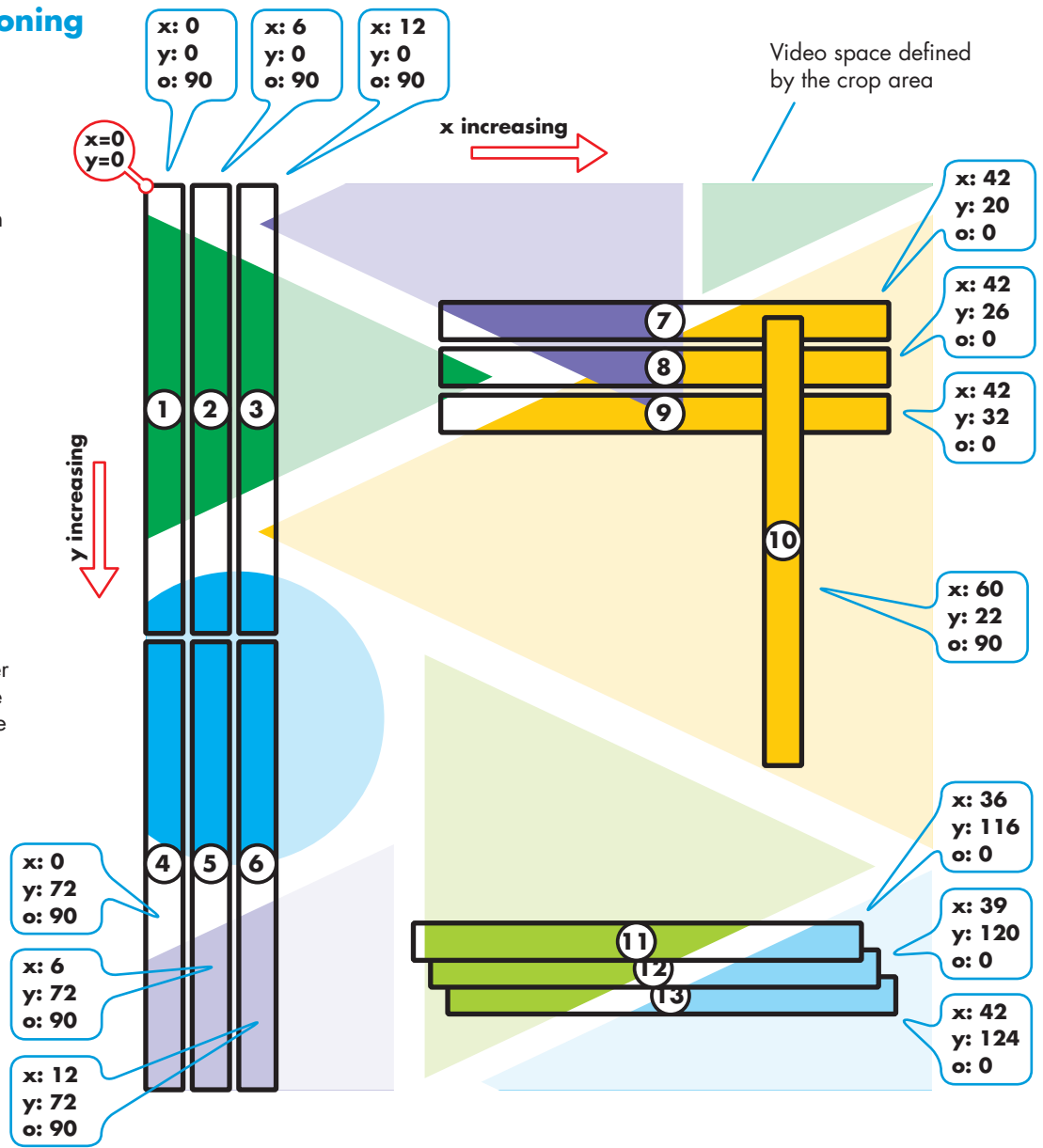

## Positioning PixelArt fixtures

There are two main ways to determine the PixelArt fixture positions:

- Use the Fixture Mapping tab within the PixelArt Setup Utility
- or
- Use a spreadsheet (e.g. Microsoft® Excel®) to create a (.csv) file that can be loaded into the PixelArt Setup Utility

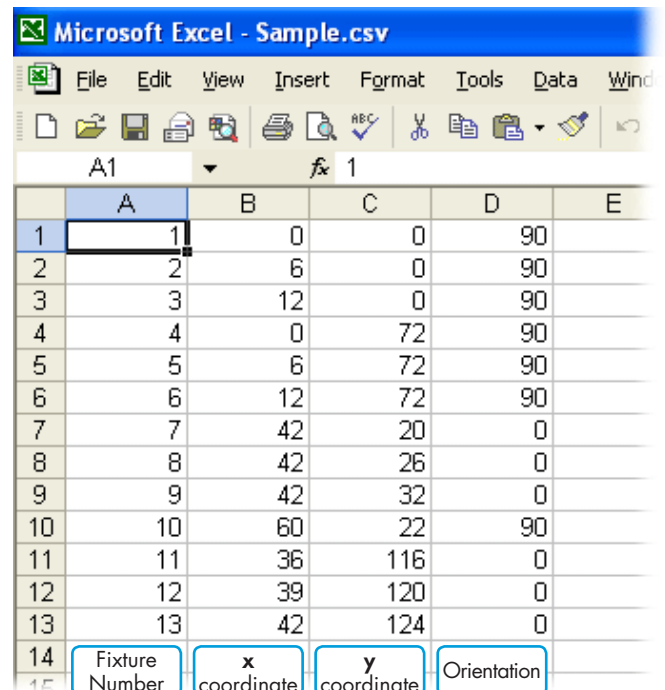
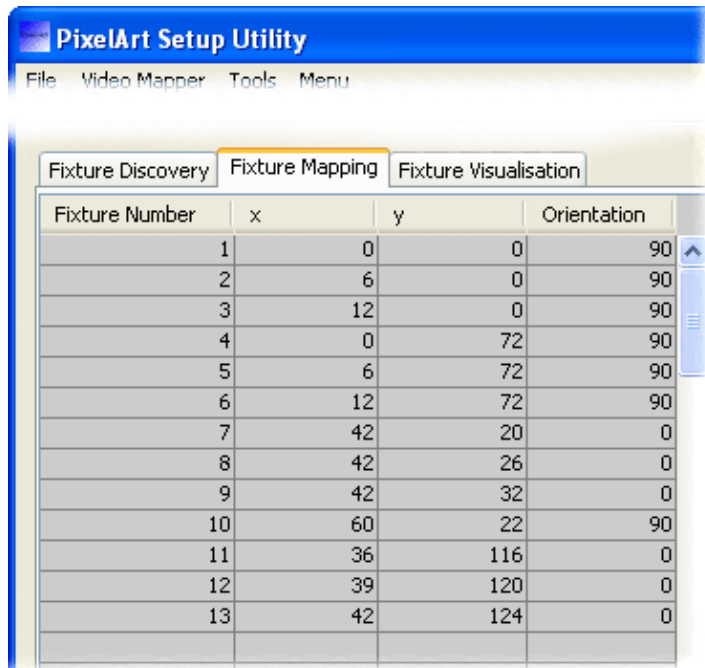

## Troubleshooting

### No video output on PixelArt fixtures

- Check that the blackout option is not active on the Video Mapper.
- Check the video input to the Video Mapper.
- Check that the fixtures are correctly mapped within the crop area.
- Check the indicators at the rear of the PixelArt fixtures for general illumination and also for error flashes.
- Check the power input fuses and the power feed to the fixtures.

### Incorrect or garbled output from one or more PixelArt fixtures

- In the PixelArt Setup Utility on the computer, click the 'Tools' menu and select the 'Initialise Fixtures' option.

### No communication between computer and Video Mapper

- Check network connection and also network address of computer.

### Settings keep being lost from the Video Mapper

- After making changes within the Video Mapper menu, be sure to go to the 'Configuration' section and choose the 'Save' option. This will store all settings within non-volatile memory. This is particularly important for network settings as these could affect the next power up of the Video Mapper.

## Dimensions

