

## General set up

- 1 Mount the fixture in the required position. The integral yoke can act as a floor stand or hanger.

### Important

- When suspended off ground, always use a safety wire rated to a minimum of 34kg (75lbs) around the yoke.
- Do not position the fixture close to fog machines. The fog oil mist will be drawn in by the cooling fan and will short out important components. The warranty will be void for all fixtures returned in such a condition.

- 2 Where external control is to be used, connect a DMX lead (XLR 5-pin female) to the input socket at the rear of the fixture.

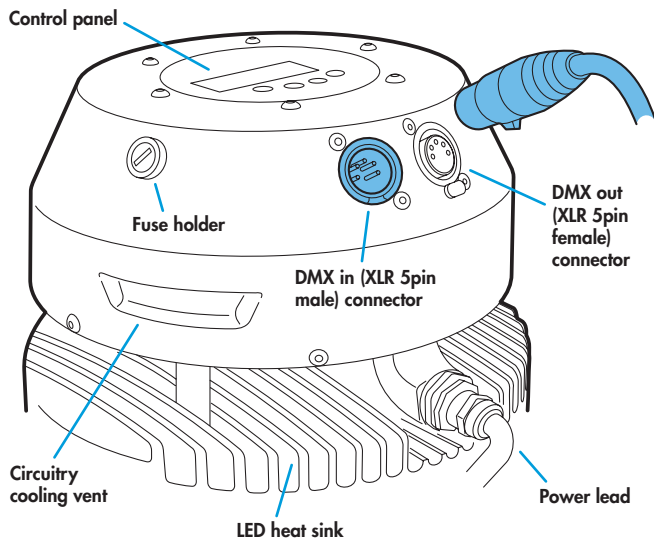

- 3 Where other fixtures are to be used in a control daisy-chain, connect a DMX lead (XLR 5-pin male) to the output socket at the rear of the fixture.
- 4 Connect power to the fixture.
- 5 Use the control panel to access the internal menu and choose the appropriate operation mode and related settings (see over).

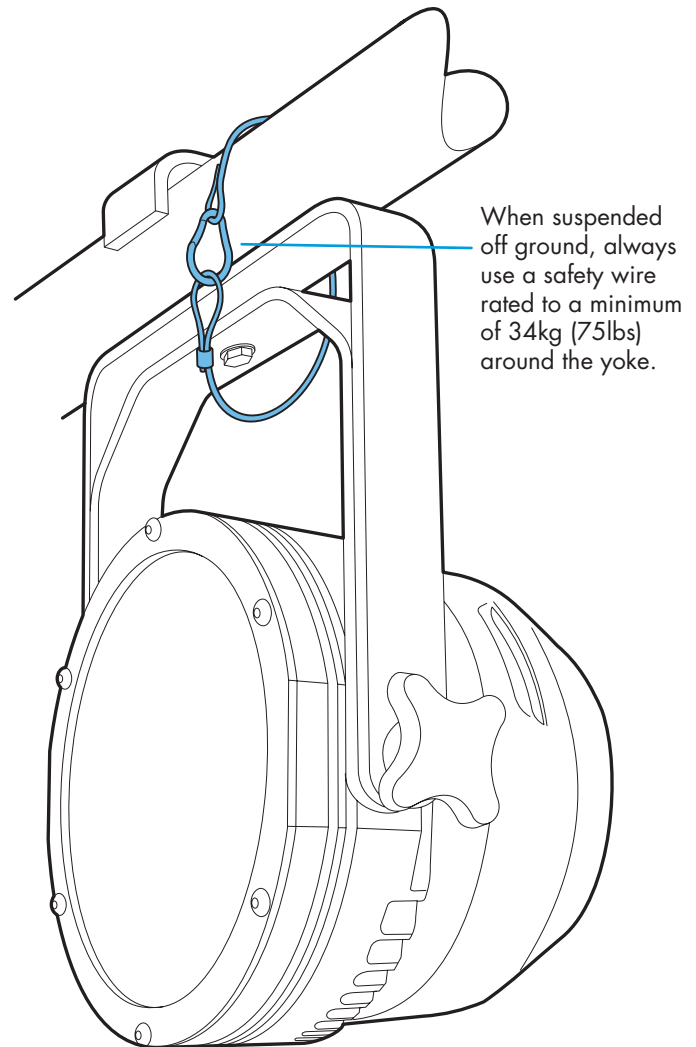
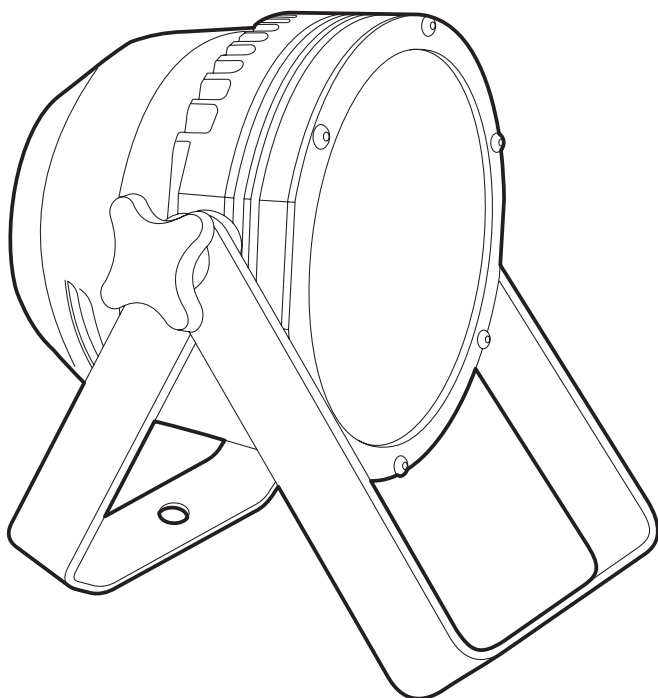

## Operation modes

The PixelPar 90 provides a range of operation modes. These are selected using the **Mode** section of the control menu:

- DM** Allows RGB control via DMX input. Internal chase effects are not available within this mode.
- MA:1** Legacy mode that makes inefficient use of DMX channels. Use **MA:2** in preference.
- MA:2** Provides control of RGB mixing and selection of the dual internal chase effects via DMX input. Requires 10 DMX channels.
- MANU** Provides RGB colour mixing independently of any external control. Use the internal control menu (**MAN** section) to select the required colour values.
- EF M** Allows the display of the dual internal chase effects, independently of any external control. Use the internal control menu (**PRGB** section) to select the required chase effects, speeds and cross fades.
- EF d** Superseded by (and operates in a similar manner to) **MA:2**. RGB mixing and chase effects cannot be used at the same time. Requires 7 DMX channels.
- EXB 1** Legacy mode that makes inefficient use of DMX channels. Use **MA:2** in preference.

PixelPar 90 personalities are available for a variety of controllers. Please see [www.pixelrange.com](http://www.pixelrange.com) for details.

## General notes

- Ensure that only one DMX device in the chain is set as master (e.g. the lighting desk). This fixture is usually set to slave mode.
- This fixture is shipped with the DMX address set to 001.
- The four digit display can be set to switch off when not in use. To restore, press **MENU**. To alter this mode use: **PER5 > DISP**.

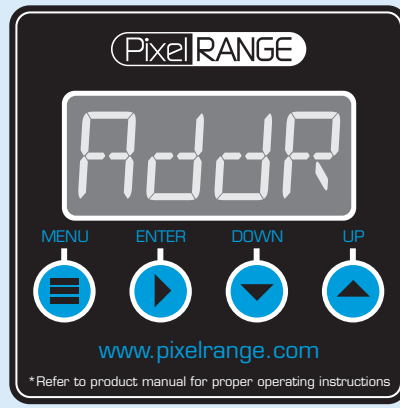

## Using the menu

- When not in the menu, the four digit display scrolls the current DMX address and mode. The display's right hand decimal point (data dot) is used to indicate status (see below).
- Press **MENU** to enter the menu. The four digit display will show **Addr**.
- Use **DOWN** and **UP** to move between menu options (or to change a value within an option).
- Press **ENTER** to enter an option (or to fix a changed value within an option and return to the previous option level). *Note: If you do not press **ENTER** to fix a value, operation will revert to the previously set mode at the next power on.*
- Press **MENU** to exit from a menu option (and eventually exit the menu completely).

## Chase effects

This section describes each of the 31 internal chase effects that are selectable either via the control menu (**PR06 > C1/C2 > EFEC**) or using DMX values sent from an external source. To use the internal effects, set the **MODE** option either to **EF 1** (to control effects via the menu) or **MR:2** (to control effects externally via DMX).

DMX value	EFEC value	Chase effect description
0-7	00	Off
8-15	01	Rainbow chase forward
16-23	02	Rainbow chase reverse
24-31	03	10/90 duty cycle strobe white
32-39	04	10/90 duty cycle strobe white
40-47	05	10/90 duty cycle strobe white
48-55	06	50/50 duty cycle strobe white
56-63	07	50/50 duty cycle strobe red
64-71	08	50/50 duty cycle strobe blue
72-79	09	50/50 duty cycle strobe yellow
80-87	10	50/50 duty cycle strobe green
88-95	11	Pulse strobe white
96-103	12	Pulse strobe blue
104-111	13	Pulse strobe rainbow
112-119	14	Pulse strobe red/green/blue
120-127	15	Primary/secondary chase
128-135	16	Rainbow chase
136-143	17	Yellow/blue chase
144-151	18	Rainbow chase
152-159	19	Yellow/blue chase
160-167	20	Red/blue chase
168-175	21	Red/green chase
176-183	22	Rainbow chase
184-191	23	Purple/white/green chase
192-199	24	Rainbow chase
200-207	25	Static orange
208-215	26	Static yellow
216-223	27	Static light blue
224-231	28	Static purple
232-239	29	Static red
240-247	30	Static green
248-255	31	Static blue

## Chase effects and master intensity channel layouts

The table below shows how the chase effects and master intensity controls are mapped to DMX channels for each mode. Mode **dm:1** does not use chase effects. The first channel of the fixture occurs at the DMX address selected using **Addr** and successive channels for the fixture follow from there. **MR:1**, **EF 1** and **ES:1** are legacy modes which do not provide the best performance. You are recommended to use **MR:2** for combined RGB colour mixing and chase effect control.

Control	MR:1	MR:2	EF 1	ES:1
C1 Effect	Ch55	Ch4	Ch1	Ch56
C1 Speed	Ch56	Ch5	Ch2	Ch57
C1 Xfade	Ch57	Ch6	Ch3	Ch58
C2 Effect	Ch58	Ch7	Ch4	Ch59
C2 Speed	Ch59	Ch8	Ch5	Ch60
C2 Xfade	Ch60	Ch9	Ch6	Ch61
RGB master intensity	None	None	None	Ch55
Effects master intensity	None	None	None	Ch62
Combined master intensity	Ch61	Ch10	Ch7	None

### Note

When using **dm:1** mode for colour mixing (no chase effects possible) and the **MINT** option is enabled, ensure that the **PER5 > RES** option is set to **3Ch**. This will ensure that the master intensity channel occurs immediately after the red, green and blue control channels, at channel 4.

## Master/slave/data indication

The right hand decimal point (data dot) of the display is used to indicate the master/slave settings and also the presence of a DMX input signal, as shown below:



<b>Data dot ON</b>	Master mode
<b>Data dot FLASHING</b>	Slave mode (DMX data input present)
<b>Data dot OFF</b>	Slave mode (no DMX data present)

### Notes:

- Ensure that only one DMX device in the chain is set as master (e.g. the desk).
- Use **PER5 > dPTR** to change between master and slave modes.
- When set to master mode, the fixture will scroll **MASTER** in place of a DMX address (when not within the menu).
- If the display has been set to auto off (**DISP > R0FF**), the data dot will remain active but at a lower brightness.

## Control menu contents

**Addr** DMX 001

Sets the base DMX address from which the control channels will begin.

**Info** VER CPU 1 00

Shows the main processor software revision. No changes are possible within this option.

DISP 1 00

Shows the display controller software revision. No changes are possible within this option.

**Prog** C1 EFEC 00

Selects the primary internal chase effect. See *Chase effects* for descriptions. Select **Mode** > **EF M** to show the selected chase.

XFAD 000

Selects the cross fade speed between the steps of the selected C1 chase effect.

SPEd 000

Selects the speed of the selected C1 chase effect.

LEVl 255

Selects the master intensity level of chase effects C1 and C2.

C2 EFEC 00

Selects the secondary internal chase effect. See *Chase effects* for descriptions. Select **Mode** > **EF M** to show the selected chase.

XFAD 000

Selects the cross fade speed between the steps of the selected C2 chase effect.

SPEd 000

Selects the speed of the selected C2 chase effect.

**MAN** RED 255

Sets the red intensity. Select **Mode** > **MANU** (manual) to show the result.

GRN 255

Sets the green intensity. Select **Mode** > **MANU** (manual) to show the result.

BLUE 255

Sets the blue intensity. Select **Mode** > **MANU** (manual) to show the result.

**PERS** RES 54Ch

Legacy option, which should be set to 3Ch for best results when using **dmx** mode. Thus, if **MINT** is set on, the master intensity channel will occur at channel 4.

DATA SLAV

Determines whether this fixture will act as a master controlling others. When controlled via DMX this fixture must be set to **SLAV**.

MINT OFF

**dmx** and **E:B 1** modes only. When set **ON** this enables the master intensity channel (ch55 for **E:B 1**, variable for **dmx**). This option must be set **ON** for **E:B 1** mode.

RSET NA

Legacy option that is no longer available.

dINT 15

Determines the intensity of the four digit control panel display and blue status indicators. Values range from 0 (dimpest) to 15 (brightest).

DISP ON

When set to **OFF**, the control panel display will blank out 60 seconds after the menu is exited. The blue status indicators will remain active.

**Mode** DMX

RGB control using variable DMX channels determined by **PERS** > **RES** setting. **MINT** set to **ON** provides a master intensity. No chase effects are selectable.

MANU

Displays the resulting RGB levels that are set via the **MAN** section of the internal menu. External DMX control is not possible in this mode.

EF d

Ch1 to 3: C1 Effect, Speed & Xfade, Ch4 to 6: C2 Effect, Speed & Xfade, Ch7: Master intensity, Ch8-10: RGB.

EF M

Displays the chase effect(s) determined within the **PRoG** section. External DMX control is not possible in this mode.

ExB 1

Legacy mode which makes inefficient use of DMX channels. Use **MAX2** in preference.

MAX 1

Legacy mode which makes inefficient use of DMX channels. Use **MAX2** in preference.

MAX2

DMX Ch1 to 3: RGB, Ch4 to 6: C1 Effect, Speed & Xfade, Ch7 to 9: C2 Effect, Speed & Xfade, Ch10: Master intensity.

## Using master mode to drive other units

This unit can control any number of other Pixel Range fixtures via DMX links, without the need for a control desk.

- 1 Set this unit as **master** (*PER5 > dATA > MAST*) and ensure all others are set to **slave** (*PER5 > dATA > SLAV*). Connect all fixtures via DMX daisy-chain.
- 2 Set each slave to *ModE > dM*.
- 3 Set each slave DMX address (using *AddrP > dM*) according to the following:

18 cells are output in groups of 3 DMX channels to give RGB values per cell (54 channels in total). Set the address of each slave fixture according to which of the 18 cells you want them to appear within, or to begin with (for multi-cell fixtures): (*ADD 1* for cell 1, *ADD 4* for cell 2, ... *ADD 2* for cell 18). Set RGB slave fixtures to 3 channel mode (using *PER5 > RES > 3Ch*).

- 4 Set the master to *ModE > EF M* (the master unit's DMX address is ignored). On the master, choose the required effects to display and send to the slave fixtures using *PR06 > C 1* and *C 2*.

## Troubleshooting

### Fixture remains at blackout when illumination expected

- If the display panel is not showing any indication, even after a button press, check the input power and fuse.
- If live DMX is connected, the right hand decimal point on the display should flash - if not, check the DMX cable and the desk output.
- Check that the selected *ModE* matches the desk personality being used.
- The master intensity channel for the current mode may be set at zero. For *EF 1* and *dM* modes, check the setting of *PER5 > MINT*. For *EF 1* mode, *MINT* must be set *off*.
- Ensure that only one DMX device in the chain is set as master.
- Standalone chase effects: Effects programmed using *PR06 > C 1* and *C 2* but the fixture is not in *ModE > EF M* mode. Check also that *PR06 > LEVL* is not set at zero.
- Standalone RGB mixing: Colour values set within *MAN* section but the fixture is not in *ModE > MANU* mode.

## Fuse access

The single fuse is located at the rear of the fixture near to the DMX input connector. Use a small flat blade screw driver to twist the fuse holder anticlockwise until the carrier can be extracted to reveal the fuse.

Fuse type: 20mm 2A (T2AH)  
anti-surge, ceramic body

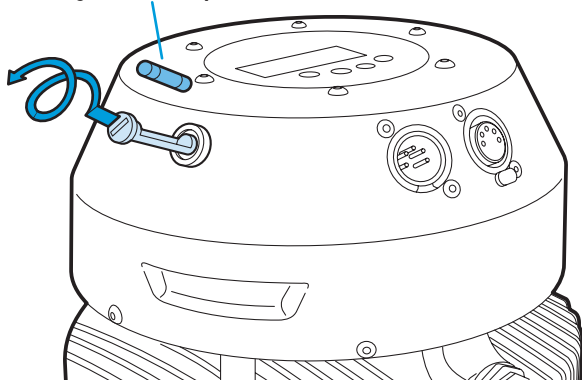

## Specifications

### Dimensions

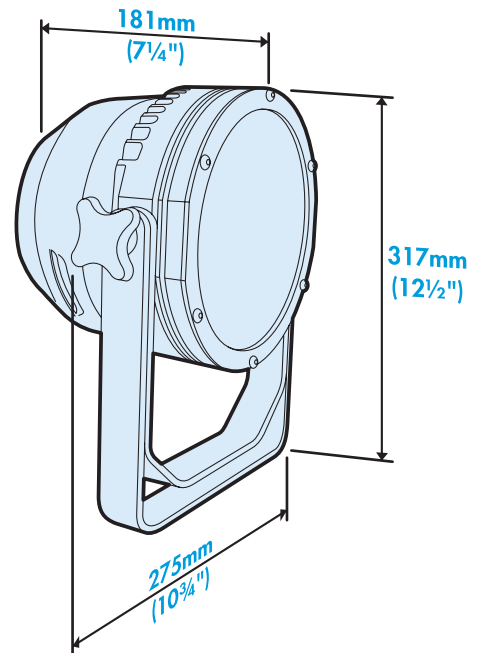

### Weight

Fixture and yoke: 6.8kg (15 lbs)

### Power

Input voltage:	90 to 264V AC, 47 to 63Hz autosensing	
Earth leakage	0.39mA	
Connectors:	Supplied with cable only: live, neutral & earth	
Power requirements:	@ 230V/50Hz	@ 115V/60Hz
Standby	10 watts	10 watts
Maximum (const.)	110 watts	110 watts
Start up (peak*)	30 amps	15 amps

\* The peak value occurs only at first power up and lasts only for a period measured in microseconds.

### Approvals



### Miscellaneous

Enclosure rating: IP20 (not protected against moisture ingress)  
Control input: USITT DMX512 (input connector pin out below)

